

CHAPTER 17

Electrical Hazards

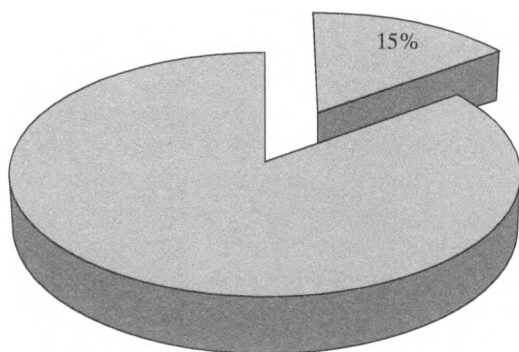

Percentage of OSHA General Industry citations addressing this subject

Everyone knows that electrical shock can be fatal, but the mechanism of the hazard is a mystery to most people. The mystery is due in large part to the fact that electricity is invisible. The use of electricity throughout our homes has led to a degree of complacency, which is a factor in most electrocutions. Besides electrocution, there are other hazards of electricity, such as fire and arc flash burn. This chapter will address each of these hazards, but will begin with electrocution because of the mystery surrounding this hazard.

ELECTROCUTION HAZARDS

The first step toward safety from electrocution is to overcome the myth that “ordinary 110-volt circuits are safe.” The truth is that ordinary 110-volt circuits can easily kill, and actually do kill, many more people than do 220- or 440-volt circuits, which nearly everyone respects. However, the myth about 110 volts persists because almost everyone has sustained an electrical shock around the home or on the job without serious injury. An accident like this leads victims to the dangerous conclusion that, although a 110-volt shock can be startling, it probably will not be fatal. Although they know that

others have been killed by such shocks, they may somehow feel resistant or too strong to be seriously injured.

It is true that some persons are more resistant to electrocution hazards than others, but a far more important factor is the set of conditions surrounding the accident. Wet or damp locations are known to be hazardous, but even body perspiration can provide the dampness that can make electrical contact fatal. Another important condition is the point of contact. If current flow enters the body through the fingers and passes out through a contact at the elbow, no vital organs receive direct exposure. However, if the flow is from a hand through the body to the feet, vital organs such as the heart, chest muscles, and diaphragm are affected, with possibly fatal results. Contact by the body torso to complete a circuit can also produce vital exposure to electrical current. Another factor can be the presence of wounds in the skin, which can result in a much higher current flow if contact is made where the skin is broken.

Physiological Effects

The central nervous system of our bodies is the conduit of signals between our brains and our muscles, including muscles of vital organs such as the heart and diaphragm. These signals are tiny electrical voltages that tell our muscles when to contract and when to relax. An external electric shock can send currents through the body that are many times greater than the tiny natural currents within our nervous systems. These larger currents can cramp or freeze muscles into a violent contraction—one that will not allow the victim to let go of the object contacted, or one that will stop breathing or stop the heart.

The heart is obviously our most important muscle. Its function is a rhythmic contraction and relaxation, which is timed by natural electrical pulses. The heart is thus very vulnerable to any pulsating electrical current. Common electric utility power supplies alternating current that cycles at a frequency of 60 hertz. It is ironic that 60 hertz is one of the most dangerous frequencies to which the heart can be exposed. This frequency tends to cause the heart to convulse weakly and irregularly at a rate too rapid to accomplish anything, a phenomenon known as *fibrillation*. Once fibrillation starts, death becomes a real threat and will certainly occur unless the fibrillation is overcome and stopped, either naturally or by controlled electrical shocks to the heart muscle by means of a defibrillator device. The controlled electric shocks reestablish the heart's natural rhythms. Unfortunately, a defibrillation device is rarely available soon enough to save the life of an electrocution victim.

Stopped breathing from electric shock is due to cramped muscles responsible for respiration, such as the diaphragm and those controlling rib cage expansion. The first-aid remedy is artificial respiration, the same as for near drowning or other respiratory crises.

Just how much electrical current is fatal? There is no set answer to this question, but Figure 17.1 summarizes the opinions of several experts. The horizontal scale is logarithmic and is in units of milliamperes or thousandths of an ampere. To put the chart in perspective, an ordinary table lamp with a 60-watt bulb draws about 500 milliamperes of current, far more than is needed to be fatal. An ordinary house circuit

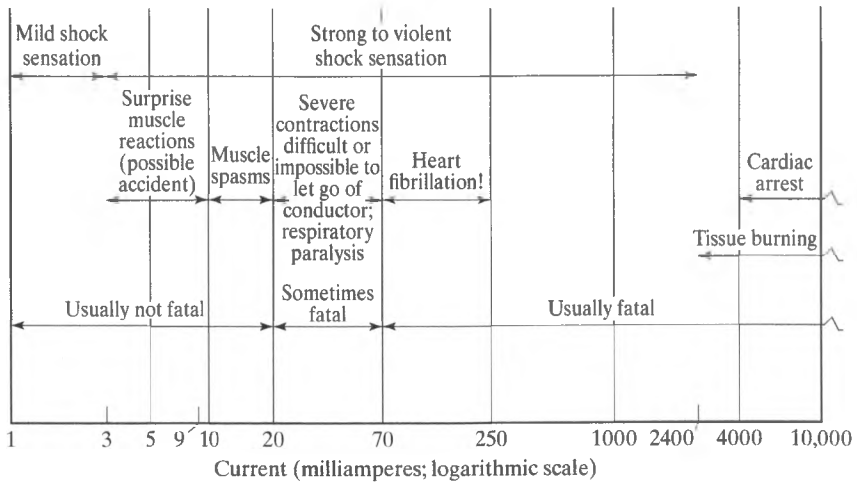

FIGURE 17.1

Effect of alternating electric current on the human body.

of 20 or 30 amperes will not trip the circuit breaker until there is a current flow of 20,000 to 30,000¹ milliamperes, respectively, about 100 to 1000 times as much as the lethal dose.

With such lethal potential available from an ordinary 110-volt house circuit, it would appear that almost no one could survive an electrical shock from such a circuit. However, the body, especially the skin, has resistance that limits the flow of electric current when exposed to 110-volt potential. To understand this resistance, some fundamentals of electricity may need review.

Ohm's Law

The basic law of electric circuits is *Ohm's law*, stated as

$$I = \frac{V}{R} \quad (171)$$

where I = current in amperes

R = resistance in ohms

V = voltage in volts

The law can be rewritten as

$$V = IR \text{ or } R = \frac{V}{I}$$

¹1 ampere = 1000 milliamperes.

Wattage is a measure of power and can be computed from known quantities of current and voltage or resistance as

$$W = V \times I \text{ and } W = I^2R \quad (17.2)$$

where W is the power in watts.

Of principal concern are alternating-current (ac) circuits, which are the predominant type in both domestic and industrial use. Standard ac circuits cycle 60 times per second (in the United States and Canada), as shown in Figure 17.2. Alternating currents are more convenient to generate and distribute than are direct currents. However, computations of current, resistance, and voltage using Ohm's law are somewhat awkward for ac circuits because the voltage varies from zero to positive, back to zero, to negative, and back to zero again every cycle. For convenience, an "effective" current for an ac circuit is computed as a value somewhat less than the current peaks. A direct current operating through a given load is found to generate as much heat as an alternating current that has peak currents 41.4% higher than the direct current. Thus, the ratio of effective current to peak current is computed as follows:

$$\frac{\text{Effective current}}{\text{Peak current}} = \frac{100\%}{100\% + 41.4\%} = 0.707 = 70.7\%$$

Effective voltages are computed by the same ratios as effective currents since they are related by Ohm's law. An ordinary 110-volt circuit then has an effective voltage of 110 volts, even though peaks of voltage over 150 volts occur every cycle.

The current drawn by an ordinary 60-watt lamp bulb can be computed by arranging Equation (17.2) as

$$I = \frac{W}{V} = \frac{60 \text{ W}}{110 \text{ V}} = 0.55 \text{ A}$$

Since the wire and other parts of the circuit would consume some power, a fair approximation to the current flow in the 60-watt table lamp is $\frac{1}{2}$ ampere, or 500 milliamperes, as stated earlier.

Returning now to the question of why more people are not killed by ordinary 110-volt circuits, we can use Ohm's law to determine how much the skin can limit the flow of electric current through our bodies. Human skin, if it is dry enough, is a good

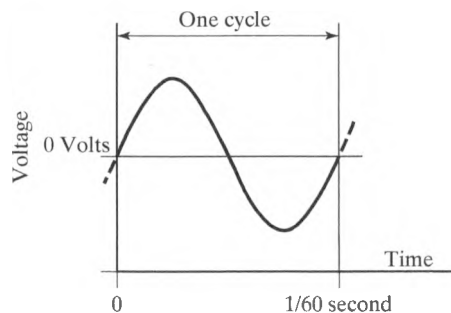

FIGURE 17.2
Alternating-current voltage.

insulator and may have a resistance of 100,000 ohms or more. By using Ohm's law, a 110-volt exposure then would result in only a tiny current:

$$I = \frac{V}{R} = \frac{110 \text{ V}}{100,000 \text{ ohms}} = 0.0011$$

$$= \text{approximately } 1 \text{ mA}$$

From Figure 17.1, it can be seen that such a tiny current will probably not even be noticed. However, add perspiration or any other moisture to the skin, and the resistance drops sharply. Owing to perspiration alone, the skin resistance can be reduced 200 times, to a level of about 500 ohms, with good contact with the electrical conductor. Once inside the body, the electrical resistance is very low and the current flows almost unimpeded. If the total resistance in the circuit is only 500 ohms, then the current is calculated as

$$I = \frac{V}{R} = \frac{110 \text{ V}}{500 \text{ ohms}} = 0.22 \text{ A}$$

$$= 220 \text{ mA}$$

From Figure 17.1 it can be seen that an alternating current at this level passing through the body, including the heart, will most likely be fatal. Therefore, if you have ever received an electrical shock, and most of us have, you can be glad that you were not perspiring enough, or that you did not have a good enough contact, or that the path of the current bypassed the trunk of your body, or that you were poorly grounded, or that some other resistance impeded the current. Otherwise, you would have been killed by the ordinary 110-volt circuit, no matter how resistant you think you are to electrical shock. The principles and concepts of the electrocution hazards of ordinary house current are illustrated by Case Studies 17.1 and 17.2.

CASE STUDY 17.1

A worker is using a hand-held circular saw to cut extruded aluminum strips in the manufacture of storm windows. He is holding the workpiece firmly in his left hand and holding the saw in his right hand. Aluminum is an excellent conductor of electricity, and the workpiece is making solid electrical contact with ground. In an accident that happens frequently, the worker accidentally saws the electrical cord in half. What are the probable consequences in the following three sets of circumstances:

- Case A: The tool is grounded through the third prong of the electrical plug.
- Case B: The tool is double insulated.
- Case C: The tool has a three-prong plug that is connected through an adapter to a two-hole wall socket; the tool is ungrounded.

Solution

Case A. Current will flow through the metal case of the saw handle into two paths, one through the grounding circuit, and the other through the worker's right hand, through his body, crossing through his torso and through his left hand into the well-grounded workpiece. Although the resistance through each of these paths might be relatively low, the resistance through the third prong grounding conductor should be the lower of the two, on the order of 2 to 3 ohms. A resistance as low as 3 ohms would immediately trip a 15- or 20-ampere circuit breaker, the type one would expect to find on such a circuit, as can be confirmed in the following calculation using Ohm's law:

$$I = \frac{V}{R} = \frac{110 \text{ V}}{3 \text{ ohms}} = 36 + \text{A}$$

The current flow just calculated would be in addition to whatever current might flow through the man's body and other paths to ground, including perhaps some flow through the tool itself before the accident completely severs the cord. The total current would therefore easily trip any reasonable circuit breaker and interrupt the flow of current, protecting the worker.

Case B. A double-insulated tool would have a nonconducting housing, resulting in no flow through the handle and the worker's body. The breaker would likely still be tripped as the metallic blade would make contact with both the hot wire and the well-grounded neutral. In addition, if the blade was cutting the aluminum workpiece at the time of the accident, another excellent path to ground would be through the metallic blade and into the grounded workpiece, causing an overcurrent to trip the breaker.

Case C. With no double insulation to protect the worker and no grounding conductor to trip the breaker, conditions might be present to cause the common accident to result in an electrocution. The well-grounded left hand of the worker would permit a substantial flow of current through his upper torso, the danger zone for heart and lung exposure. A reasonable value for the resistance in a well-grounded path through the worker's left hand and the aluminum workpiece would be 600 ohms. The current in such a grounding circuit would be calculated as follows:

$$I = \frac{V}{R} = \frac{110 \text{ V}}{600 \text{ ohms}} = 0.183 \text{ A}$$

The current just calculated, only a small fraction of an ampere, would have no effect on a normal 15- to 20- ampere circuit breaker. However small a 183-milliamperere current may be for breaking the circuit, it is a very large and dangerous current to flow through the worker's upper body. Such a current is shown in Figure 17.1 to represent a strong to violent, usually fatal, shock capable of producing heart fibrillation. The metallic blade of the saw might provide a good grounding path through the severed neutral or the well-grounded workpiece, accommodating an overcurrent that would trip the breaker and save the worker's life. However, such a grounding through the metallic blade would be dependent upon chance; without such grounding, the accident would likely be fatal.

CASE STUDY 17.2

A worker uses a trouble light suspended from the hood of an automobile while he repairs the engine. He leans across the fender of the car as he works so that his chest makes firm contact with the metallic fender, although that contact is resisted somewhat by a thin T-shirt he is wearing and slightly by the paint on the fender of the automobile. The light, which has been through many years of severe usage, has developed a worn connection at the point at which the flexible cord is connected to the lamp socket. As the worker adjusts the light's position the worn connection results in accidental contact between the worker's index finger and the hot wire. Current passes through the man's finger and arm, continuing through multiple paths through his torso, most of it flowing to ground through his chest and the fender of the automobile and some through his feet and shoes. The contact between the hot wire and man's finger is only partial, and the electrical resistance of the skin in the man's finger at the point of contact is about 800 ohms. If this resistance represents about half the effective total resistance in the short circuit, how much current would flow through the man's torso? Would the circuit breaker, rated at 15 amperes, be tripped? Would the shock likely be fatal?

Solution

In this situation the current would flow through many parallel paths through the man's body, but for purposes of considering the total current flow due to the short circuit, one can consider the path to be equivalent to one effective path with a resistance of twice 800 ohms, or 1600 ohms. Using Ohm's law, we find that

$$I = \frac{V}{R} = \frac{110 \text{ V}}{1600 \text{ ohms}} = 0.069 \text{ A}$$

$$= 69 \text{ mA}$$

Such a current flow is much too small to trip the 15-ampere breaker, even if combined with the current flow through a 60-watt lighted lamp, which was calculated earlier in this chapter to be 0.55 ampere. If the entire 69-milliamper short circuit passes through the central part of the man's body, he is in critical danger of electrocution. Figure 17.1 reveals that 69 milliamperes is in the region of "sometimes fatal" and "respiratory paralysis." The victim may survive if an alert bystander is trained in cardiopulmonary resuscitation and applies artificial respiration, and if the victim is fortunate enough to avoid heart fibrillation.

Grounding

In the previous discussion, the term *grounded* was used. Just what does this electrical term mean? A requirement for electrical current to flow is that its path make a complete loop from the source of electrical power through the circuit and back again to the power source. We understand this loop as we connect a lantern bulb to the posts of a lantern battery, as shown in Figure 17.3. Disconnection of the circuit at any point in

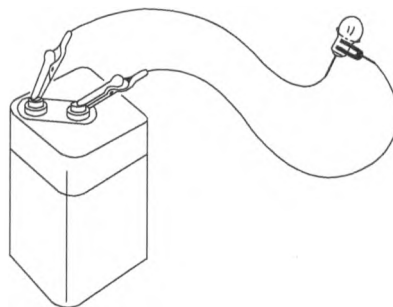

FIGURE 17.3

An electrical circuit makes a complete loop.

the complete loop stops the flow of current. This means that there must always be two conductors: one to carry the current to the device (usually called the “load”) that uses it and another to carry the current from the load back to the electrical source. However, a trick makes the long trip back to the electrical source very simple in most applications of electrical power.

The earth for the most part is a fairly good conductor of electricity. Besides this, it is so massive that it is difficult for a man-made source of electricity to affect it much one way or another. Thus, no matter what we do on the surface of the earth, the earth maintains a relatively even potential or charge. This means that if we drive two stakes firmly into the earth, even at great distances from each other, we may consider the resistance between them to be nil. The current flow may not be directly from one stake to the other because there are millions of electrical contacts to the earth at all times. Some of these contacts are positive and some are negative, but the total result is zero or earth potential. Thus, any electrical conductor driven into the earth immediately assumes the zero reference potential of the earth. This is a very convenient characteristic of the earth because it enables us to use it as one great common conductor back to the source of power. Figure 17.4 illustrates the use of the ground as a return conductor.

A careful examination of Figure 17.4 reveals that the power company provides a separate neutral conductor for the completion of the circuit back to the source. There are conditions that make dependence on the common potential of the earth somewhat unreliable. A very dry season, for instance, may make the surface of the earth lose its conductivity. This is especially a problem if the area is dry around the grounding conductor stake that has been driven into the ground. The neutral conductor then ensures the completion of the circuit regardless of conditions.

The use of ground in electrical circuits is so advantageous as to be considered indispensable. However, the very convenience and proximity of the ground everywhere present a hazard. If a person contacts an energized conductor and at the same time is in contact with the ground or some other object that has a conductive path to ground, that person completes the electrical circuit loop by passing electric current through his or her body. A major portion of the *National Electrical Code*² is devoted to prevention of this hazard.

²*National Electrical Code*[®], commonly abbreviated NEC, is published regularly by the National Fire Protection Association (NFPA), 470 Atlantic Avenue, Boston, MA, 02201.

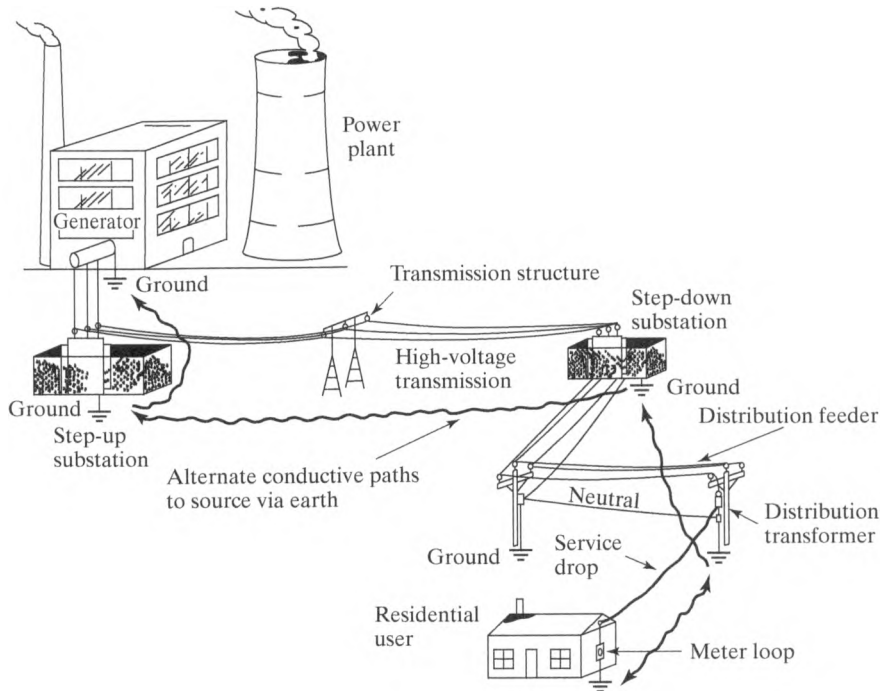

FIGURE 17.4
Alternative conductive paths to source through earth.

The principal way in which persons are protected from becoming a part of the path to ground is by insulation of conductors. In addition, exposed conductive surfaces are given a good connection to the ground, usually by means of the ground wire, so that opportunity for a person's body to be the path to ground is minimal. Paradoxically, in some rare instances, the *National Electrical Code*[®] takes exactly the opposite approach. For some systems, it makes more sense to *isolate* the entire structure from ground. If the structure is isolated, workers are protected by not being in contact with conductors that could connect them with ground.

Wiring

A typical 110-volt circuit has three wires: *hot*, *neutral*, and *ground*. Sometimes the neutral is called the “grounded” conductor, in which case the ground is called the “grounding” conductor. The purpose of the hot wire (usually a black insulated wire) is to provide contact between the power source and the device (load) that uses it. The neutral (usually a white insulated wire) completes the circuit by connecting the load with ground. Both the hot and the neutral normally carry the same amount of current, but the hot is at an effective voltage of 110 volts with respect to ground, whereas the neutral is at a voltage of nearly zero with respect to the ground.

The third wire is the ground wire and is usually either green or is simply a bare wire. The purpose of the ground wire is safety. If something goes wrong so that the

hot wire makes contact with the equipment case or some other conductive part of the equipment, the current in its path to ground can bypass the load and take a shortcut, commonly called a *short*. Since the load is bypassed, the short is a very low-resistance path to ground and by Ohm's law draws a very high current. This high current in a properly protected circuit will almost immediately either "blow" a fuse or "trip" a circuit breaker, depending on the type of overcurrent protection provided in the circuit, and stop all flow of current in the circuit.

It is possible, of course, to have a short without a ground wire. The equipment may be naturally grounded by its location or installation, or the hot wire can somehow contact the neutral. Sometimes the short to ground is only partial because there is considerable resistance in the short path to ground. Such a short may go undetected because the short flow of current is of insufficient amperage to cause the total circuit current to trip the overcurrent protection in the circuit. In this case, current will continue to flow, and equipment loads will continue to operate in the presence of these shorts, or *ground faults*, as this type of short is sometimes called. Such ground faults can be especially dangerous on construction sites. This hazard is the basis for ground-fault circuit-interruptor (GFCI) devices on construction sites. The GFCI protection is in addition to overcurrent protection such as circuit breakers or fuses.

Figure 17.5 explains how a GFCI works. Whenever the current flow in the neutral is less than the current flow in the hot wire, a ground fault is indicated, and the current flow is stopped by a switch that breaks the entire circuit. Building codes have required the installation of GFCI circuits in residential bathrooms. GFCI electrical receptacles have small, red "RESET" buttons, as shown in Figure 17.6. One difficulty with GFCIs is that some leakages to ground are almost impossible to prevent, especially when conditions are wet or extension cords are extremely long. This causes the GFCI to trip even when no hazard exists, a condition known in the construction industry as *nuisance tripping*. An alternative to GFCIs is for the employer to test, inspect, and keep records of the condition of equipment grounding conductors.

One misconception about shorts is the idea that a good fuse or circuit breaker is sufficient to stop the flow of a dangerous short through a person's body. A reexamination of Figure 17.1 shows that a person will almost certainly be killed by exposure to a current that would not blow even the smallest popular household fuses (i.e., 15- or 20-ampere fuses). A fuse or breaker rated at 15 amperes will handle up to 15,000 milliamperes before

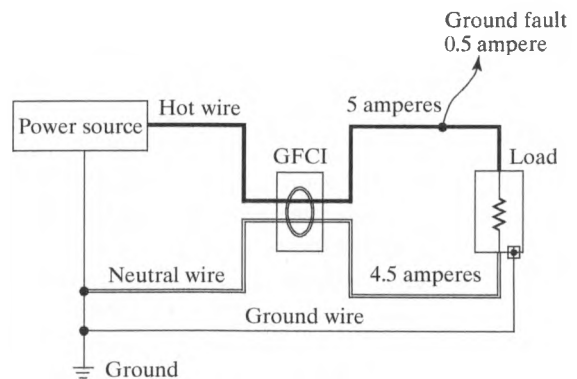

FIGURE 17.5

Ground-fault circuit interruptor (GFCI). The 0.5-ampere fault to ground causes a current flow imbalance between the hot and the neutral. This imbalance triggers the GFCI to break the circuit.

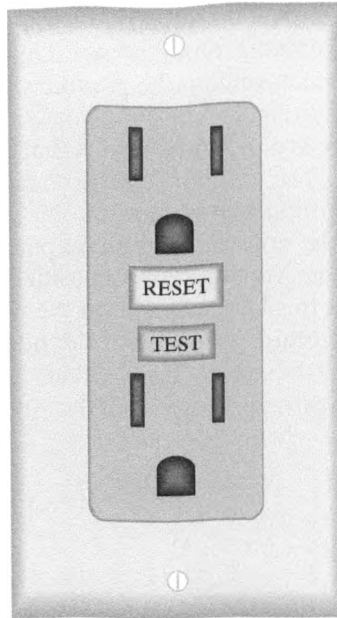

FIGURE 17.6

An electrical receptacle equipped with a GFCI.

blowing, several times as great as the fatal current shown in Figure 17.1. The beauty of the third wire or grounding wire is that it provides a very low-resistance, high-current short to ground, which will trip the fuse or breaker immediately, before *other* short paths to ground (such as through a person's body) can do their damage.

Double Insulation

Unfortunately, less than half of the electric hand tools in actual use are properly grounded. Studies of equipment returned to the factory for repair have shown that a large number of units have been altered so that the grounding system is no longer intact. A common alteration is to cut off the third prong of the plug so that it can be plugged into an old two-wire receptacle. To counter this practice, the use of "double-insulated" tools is permitted in lieu of equipment grounding. A second covering of insulation gives an extra measure of protection to the operator of double-insulated tools in case of a short to the equipment case.

Most double-insulated tools have a plastic, nonconductive housing, but this is not a fully reliable indication that the tool is double insulated. The second covering of insulation must be applied according to precise specifications before the tool can qualify to receive the designation "double insulated." Qualifying tools have the manufacturer's mark "double insulated" or a square within a square \square to indicate double insulation.

Miswiring Dangers

In the original wiring job, electricians sometimes make mistakes or use slipshod practices that increase hazards. One of these practices is to "jump" (connect) the ground wire to the neutral wire. Actually, this is a trick that will work, and usually no one will be the

wiser, but the practice does cause hazards. Figure 17.7 shows how a circuit is correctly wired, revealing that both the neutral and grounding wire are connected directly to ground. So in Figure 17.8, in which it is shown that the ground is jumped to the neutral, a third wire is not used in the wiring system.

The main hazard in jumping the ground to neutral is that it can create low voltages on exposed parts of equipment. The equipment case or housing is connected to the ground wire. Since no current normally flows through the ground wire, it serves as an excellent method of keeping the voltage on the equipment case close to zero with respect to ground. However, the neutral does carry considerable current. By using Ohm's law, it can be determined that this large current on the neutral may cause it to have a low voltage with respect to ground, especially if the neutral wire must travel a long distance back to the ground at the meter. If the circuit is carrying a current of 20 amperes and the resistance of the neutral wire is $\frac{1}{2}$ ohm, the voltage on the equipment case is calculated to be

$$V = IR = 20 \times \frac{1}{2} = 10 \text{ V}$$

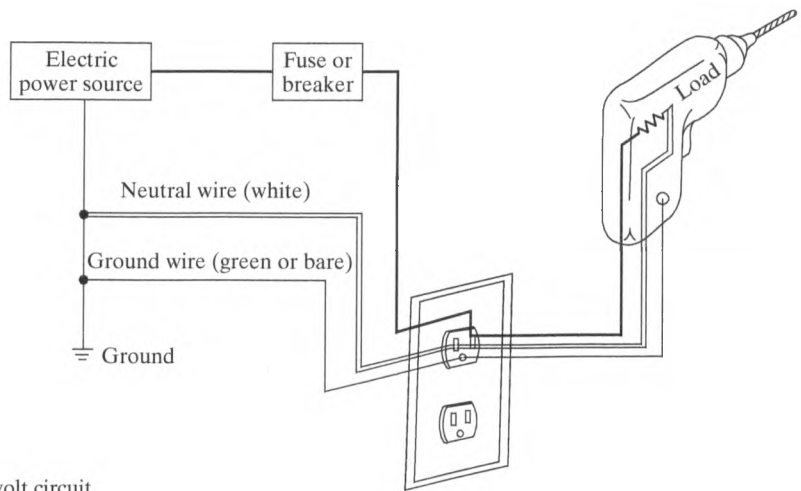

FIGURE 17.7
Correctly wired 110-volt circuit.

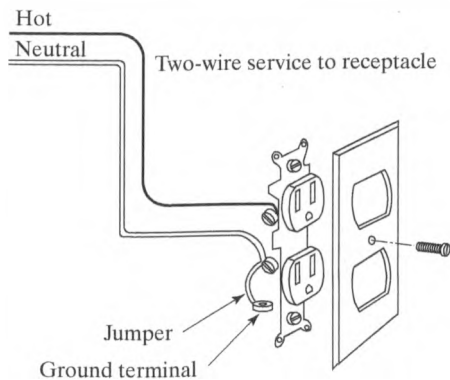

FIGURE 17.8
Ground jumped to neutral.

This is a low voltage, but is theoretically capable of producing a fatal current through a person's body if conditions are just right (or rather, wrong). The real hazard, though, is that a loose or corroded connection somewhere in the neutral circuit would increase its resistance, perhaps to 4 or 5 ohms, causing the voltage to increase several times.

Another common wiring mistake is *reversed polarity*, which simply means that the hot and neutral wires are reversed. This is another subtle problem because most equipment will operate perfectly well with reversed polarity. One hazard of reversed polarity is that the designated leads (black lead, hot; white lead, neutral) become reversed, and the confusion could bring on an accident to an unsuspecting technician. Another hazard is that a short to ground between the switch and the load could cause the equipment to run indefinitely, independent of whether the switch is on or off (see Figure 17.9). Finally, bulb sockets can become hazardous when the polarity is reversed. In Figure 17.10(a), a correctly wired socket shows the screw threads to be neutral. However, in a reversed-polarity socket, as shown in Figure 17.10(b), the exposed screw threads become hot, and the button, which is naturally more protected at the bottom of the socket, becomes neutral.

Perhaps the most common wiring mistake of all is to fail to connect the ground terminal to a ground wire, a condition known as *open ground*, or *ground not continuous*. This is another error that can easily go unnoticed because equipment attached to circuits

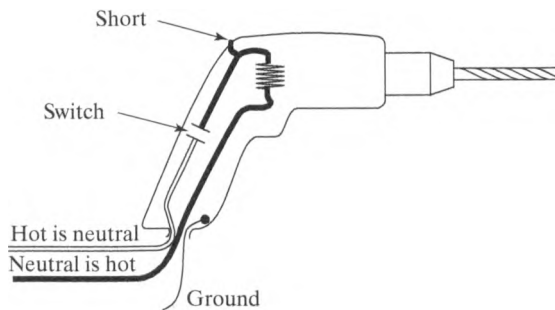

FIGURE 17.9

Reversed polarity. A short in the position indicated in the circuit for this drill will cause the drill to operate continuously, independent of the switch.

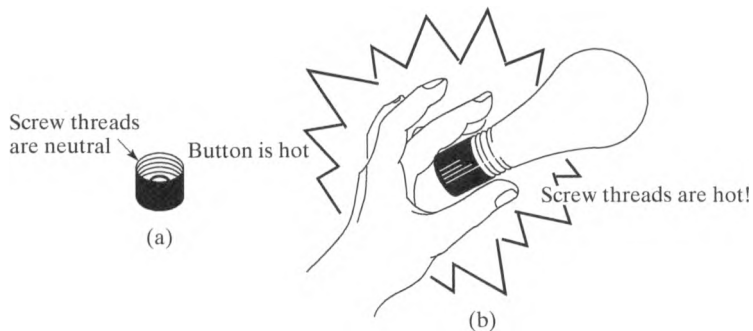

FIGURE 17.10

Hazards of reversed polarity in lamp socket: (a) correctly wired socket; (b) reversed-polarity socket.

miswired in this way will usually operate normally. However, if an accidental short to the equipment case occurs, the worker is in danger of electrocution.

The three cases of miswiring discussed in this chapter are not the only mistakes that can be made in wiring electrical circuits; they are not even the most hazardous. However, because they permit electrical circuits to “work normally,” they go unnoticed by uninformed users of equipment attached to such circuits. Because the errors are not immediately crippling to the function, they are frequently committed. Some simple checks with inexpensive testers can easily reveal the problems. These testers will be examined later.

FIRE HAZARDS

Most people think of electrocution when they think of electrical safety, but electrical codes have as much to do with fire hazards as they do with electrocution. Many systems, such as fuses or circuit breakers, protect against both fire and electrocution, but their primary function is fire prevention.

Wire Fires

One of the most common causes of electrical fires is wires that become overheated because they conduct too much current. Wire diameters (gauges) must be properly sized to handle the expected current load, and overcurrent protection (fuses or breakers) must ensure that these loads are not exceeded. Substitution of fuses with copper pennies is a common method of defeating the overcurrent protection so that the circuit will handle larger loads. If no fuse is present to burn in two, the wire itself may act as the next weakest link. If the wire becomes hot enough to burn in two, any contact with combustible material along the wire run is likely to produce a fire.

Arcs and Sparks

Whenever two conductors make a physical contact to complete a circuit, a tiny (or not so tiny) electric arc jumps the air gap just prior to contact. This arc may be so small as to be undetectable, but it is usually hot enough to ignite explosive vapors or dusts within their dangerous concentration ranges.

When the electric arc is an instantaneous discharge of a statically charged object, it is sometimes called a *spark*. Such sparks are capable of igniting an explosive mixture, the spark plug of an automobile engine being ample testimony. Sparks are prevented by electrically connecting, or “bonding,” two objects that may be of different static charge. This is especially important when pouring flammable liquids from one container to another.

The arc that occurs when an ordinary electrical circuit is completed is virtually impossible to prevent. This means that switches, lights, receptacles, motors, and almost any electrical device, even telephones, are a source of ignition to hazardous concentrations of explosive vapors or dusts. Chapter 11 discussed the ranges of explosive vapors and defined the lower and upper explosive limits (LEL and UEL, respectively). Since the arc is impossible to prevent, some means must be used to separate it from the hazardous

concentrations in the air. This is done by using wire, conduit, or equipment that is either vapor tight or strong enough to contain and prevent the propagation of an explosion inside the conduit or equipment. This is an expensive undertaking, and it is tempting to take shortcuts. The *National Electrical Code*[®] has a strict code for electrical wiring and equipment designed for hazardous locations. The safety and health manager should be able to identify the operations or hazardous locations within the plant that require special wiring and electrical equipment. Accordingly, this identification scheme is discussed next.

Hazardous Locations

One of the most difficult tasks in the field of industrial safety is the definition of various industrial locations that require special wiring and equipment to prevent explosions. Industrial processes are so diverse as to defy a general definition. In addition, the ignition mechanisms are different for different materials. For instance, the hazard of heat buildup on electric equipment housings and bearings coated with ignitable dusts is altogether different from the hazard of spark ignition of explosive vapors derived from flammable liquids. Difficult as the problem is, it must be dealt with because some industrial locations are just too dangerous to allow exposure to electric ignition sources.

The *National Electrical Code*[®] meticulously defines various conditions to classify hazardous locations roughly into six categories. Within these classifications are various groups that identify the substance group that is causing the hazard.

The major classification is according to the physical type of dangerous material present in the air and is designated *Class*. The next classification is called *Division* and relates to the extent of the hazard by considering the relative frequency with which the process releases hazardous materials into the air. The criteria for "Division" are subjective, not quantitative, except around paint spray areas. This subjectivity introduces problematic gray areas.

Figure 17.11 is a decision chart that attempts to simplify the complicated process of the classification of hazardous locations. The chart is approximate only because strict definition would require enumeration of pages of exceptions and conditions, many of which would overlap. The thing to remember is that the "Class" is the material and the "Division" is the extent of the hazard. Thus, one can state that Division 1 locations are more hazardous than Division 2 locations, but cannot state absolutely that Class I locations are more hazardous than Class II or III locations.

Since classification is so complex, industry often relies on examples common in similar industries to decide whether a location is Division 1 or 2 or not of sufficient hazard to classify at all. Examples of some common hazardous locations are listed in Table 17.1.

Equipment qualifying for hazardous locations usually qualifies for both Division 1 and 2. When in doubt, most industries want to install equipment approved for Division 1 in order to be prepared for the worst. Most violations of code are not for selection of Division 2 equipment when Division 1 should have been selected; they are from the use of thin-walled conduit and conventional electrical equipment in Division 1 or 2 locations.

"Approval" of electrical equipment for use in hazardous locations means that the manufacturer's design has been tested and approved by a recognized testing laboratory

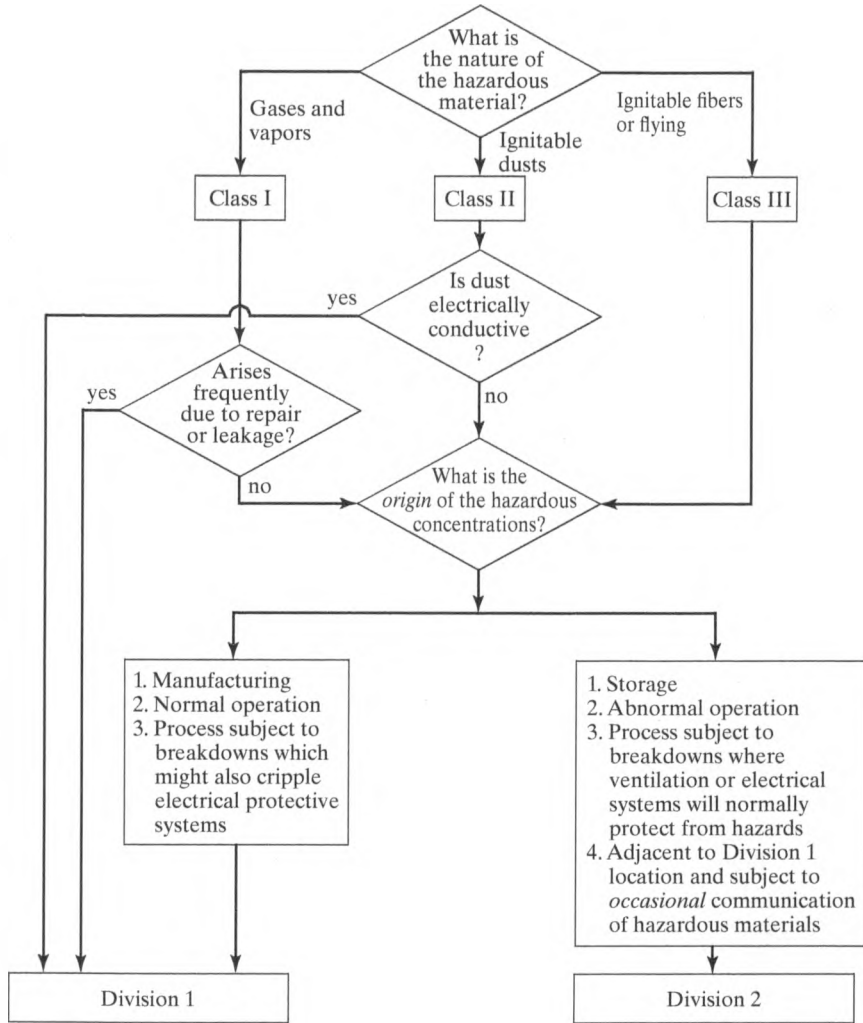

FIGURE 17.11

Decision chart for classifying hazardous locations that are dangerous from the standpoint of ignition of materials in the air.

such as Underwriters' or Factory Mutual. A label must be present on the equipment designating its classification if that equipment is to be used in hazardous locations.

Figure 17.12 shows several examples of *explosion-proof equipment* approved for Class I, Division 1 locations. Explosion-proof conduit looks more like pipe than conventional thin-walled conduit, which looks more like tubing. Explosion-proof junction boxes are castings, as opposed to conventional formed sheet metal boxes. The complicated structures for telephones and even light switches make obvious the fact that explosion-proof equipment costs several times as much as conventional equipment.

TABLE 17.1 Classification of Common Hazards

Description	Classification
Paint spray areas (flammable paint)	Class I, Division 1
Areas adjacent to, but outside of, paint spray booth	Class I, Division 2
Areas of open tanks or vats of volatile flammable solvents	Class I, Division 2
Storage areas for flammable liquids	Class I, Division 2
Inside refrigerators containing open or easily ruptured containers of volatile flammable liquids	Class I, Division 1
Gas generator rooms	Class I, Division 1
Grain mills or processors	Class II, Division 1
Grain storage areas	Class II, Division 2
Coal pulverizing areas	Class II, Division 1
Powdered magnesium mill	Class II, Division 1
Parts of cotton gin locations	Class III, Division 1
Excelsior storage areas	Class III, Division 2
Closed piping for flammable liquids (piping has no valves, checks, meters, or similar equipment)	Not classified

In Division 1 locations, it is recognized that there is no way to ensure that the vapors will be kept out of the conduit and equipment. During maintenance, installation, or other open periods, vapors will enter the system. Therefore, the electrical equipment designer assumes this inescapable reality and designs the Division 1 equipment to withstand an internal explosion and cool the explosion gases as they escape before they can ignite the entire area in a devastating explosion.

By contrast, Division 2 electrical equipment enjoys some isolation from dangerous explosive vapors *most* of the time. Therefore, if the Division 2 equipment can be properly sealed with gaskets to make it vapor tight, it will be safe. Class I, Division 2 equipment is characterized as vapor tight, whereas Class I, Division 1 equipment is *not* vapor tight but is explosion proof. Of course, if equipment is classified as Class I, Division 1 (explosion proof), it is also acceptable for use in Class I, Division 2 areas even though the equipment is not vapor tight.

The foregoing comparison of Division 1 and Division 2 equipment and locations acknowledges the generalization that any equipment approved for Division 1 locations is also acceptable for Division 2 locations *of the same classification*. However, it should be noted here that equipment approved for Class I locations is not necessarily approved for Class II or III. The hazard mechanisms of ignitable Class II dusts or Class III fibers are somewhat different from the hazards of Class I vapors. Dusts and fibers can settle on warm equipment, insulating it from necessary heat dissipation during operation. Such insulation can cause a substantial heat buildup on the equipment that can result in a smoldering dust ignition and subsequent explosion.

A common error when selecting electrical receptacles for hazardous locations is to mistake weatherproof electrical outlets for approved equipment. Ordinary weatherproof outlets, as shown in Figure 17.13, are not approved for any type of hazardous locations in either Division 1 or 2. The spring-loaded cover protects the receptacle from

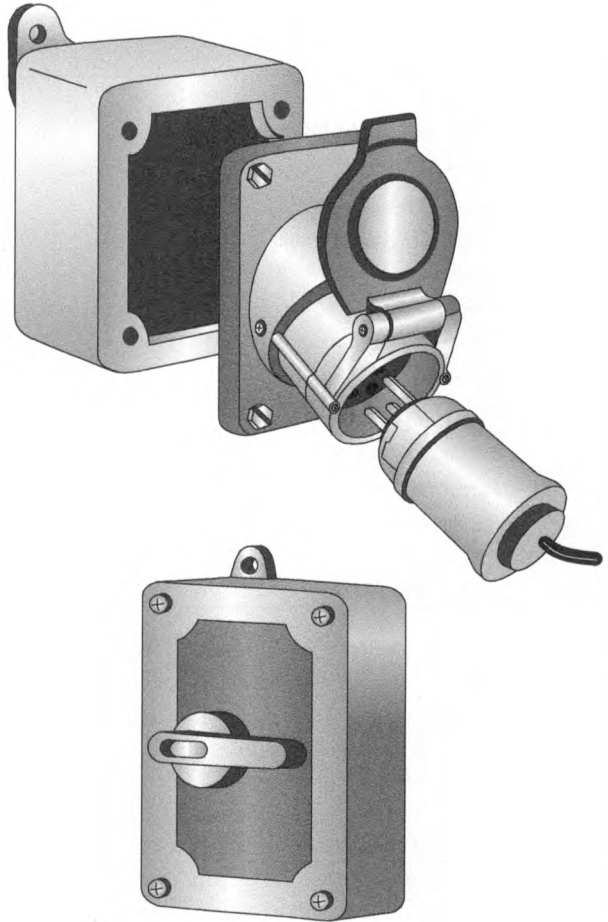

FIGURE 17.12

Explosion-proof electrical equipment approved for Class I, Division I hazardous locations. Note heavy-duty, machined components. (a) Electrical outlet plug and receptacle; (b) wall switches.

weather when the receptacle is not in use, but when a plug is inserted into the receptacle, the receptacle is exposed as much as any conventional one.

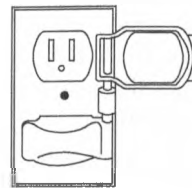

FIGURE 17.13

Ordinary weatherproof outlets not approved for hazardous locations.

The safety and health manager may be baffled when reading equipment labels to find that equipment is classified and labeled by Class and *Group*, rather than Class

TABLE 17.2 Groups and Classes

Class	Group	Description	Examples	Industries
I	A		Acetylene	Welding fuel generators
	B	Highly flammable gases and some liquids	Hydrogen	Chemicals and plastics
	C	Highly flammable chemicals	Ethyl ether, hydrogen sulfide	Hospitals, chemical plants
	D	Flammable fuels, chemicals	Gasoline	Refineries, chemical plants, paint spray areas
II	E	Metal dusts	Magnesium	Chemical plants
	F	Carbon, coke, coal dust	Carbon black	Mines, steel mills, power plants
	G	Grain dusts	Flour, starch	Grain mills and elevators

and *Division*. Like the Class designation, the Group designation identifies the type of material present in the atmosphere, but the Group classification is more detailed. Four of the Groups belong to Class I and three to Class II and are summarized in Table 17.2.

A typical classification label will state “approved for Class I, Groups A and B,” omitting the “Division” designation. When the “Division” is omitted, the classification is invariably acceptable for both Division 1 and 2 locations. If the equipment is merely vapor tight and approved only for Division 2, the “Division” designation should be displayed on the label. Class I equipment is usually either approved for Groups C and D or is approved for all four Class I Groups: A, B, C, and D.

ARC FLASH

The types of electric arc hazards discussed thus far in this chapter are the tiny arcs that can cause ignition in hazardous atmospheres whenever an electrical circuit is switched or connected. However, if the voltage is high enough, say 480 volts or higher, and there is sufficient power in the circuit to deliver a high current flow, an arc explosion can result, even in normal, nonhazardous atmospheres. The twenty-first century has seen increased attention to these high energy discharges, commonly called “arc flash.” Arc flash is so intense that it can be compared to the explosive detonation of TNT. The calculation of energy discharge is direct from the application of Ohm’s Law discussed earlier in this chapter.

For an example calculation of the powerful effects of arc flash, let us consider an accidental fault in a 480-volt circuit that is capable of delivering a current of 15,000 amperes. Recalling the formula for electrical power:

$$\begin{aligned}
 \text{Power} &= \text{voltage} \times \text{amperage} \\
 &= 480 \text{ V} \times 15,000 \text{ A} \\
 &= 7,200,000 \text{ VA} \\
 &= 7,200,000 \text{ W} \\
 &= 7.2 \text{ MW}
 \end{aligned}$$

This is a large amount of power. The amount of energy released would depend upon how long the fault remained in the circuit, hopefully only a fraction of a second. Recalling that a typical utility circuit operates at a frequency of 60 Hz or 60 cycles/second, suppose the fault current holds for approximately 20 cycles. This would amount to about 1/3 of one second. Electrical energy is measured in joules and is calculated as the power in watts multiplied by the duration of delivery of that power in seconds. Therefore, in our calculation:

$$\begin{aligned}\text{Energy} &= \text{power} \times \text{duration} \\ &= 7.2 \text{ mW} \times 20 \text{ cycles}/60 \text{ cycles/second} \\ &= 7.2 \text{ mW} \times 1/3 \text{ second} \\ &= 2.4 \text{ mJ}\end{aligned}$$

This release of energy can be compared to a blast of TNT, which releases 2175 joules of energy per g. Therefore, in our example:

$$\begin{aligned}\text{Energy} &= 2,400,000 \text{ J}/2175 \text{ J per g of TNT} \\ &= 1103 \text{ g of TNT}\end{aligned}$$

Using a weight conversion of 454 g = 1 pound, we can convert our example to pounds of TNT:

$$\begin{aligned}\text{Energy} &= 1103 \text{ g}/454 \text{ g/pound of TNT} \\ &= 2.43 \text{ pounds of TNT}\end{aligned}$$

Thus, in our example, a 1/3-second arc flash can generate the energy of almost 2.5 pounds of TNT—a powerful explosion that can cause great injury and even destroy equipment in the vicinity of the arc flash. An arc flash explosion is not exactly the same as the detonation of TNT, but it is similar in many respects. The arc flash will result in a loud explosion and some mechanical damage, but will especially release intense heat and radiation, all the way from infrared to ultraviolet.

The best defense against arc flash is to not let it happen. This echoes principles of hazard prevention and control discussed earlier in this book. The best defense is to eliminate the possibility of arc flash in the process by proper equipment selection and process design. When such measures are infeasible and there is the possibility of exposure to arc flash, personnel should be trained to understand and respect the energy potential of such an event. As a last resort there is personal protective equipment for personnel who may be exposed. Utility and maintenance workers are the most exposed category of personnel for the dangers of arc flash.

The hazard of arc flash is not as common in ordinary plant exposures as are the hazards of electrocution or fire, but arc flash is still a possibility to be considered. The safety and health manager should be aware of this hazard and be prepared to deal with it should the chance of exposure in the workplace arise. Having considered the spectrum of electrical hazards that might be present in the workplace, we now focus upon some simple items of equipment to help the safety and health manager deal with these hazards.

TEST EQUIPMENT

Pursuant to general electrical safety, there are a few inexpensive items of test equipment that the safety and health manager should have access to for occasional in-house inspections. Brief descriptions of these items follow.

Circuit Tester

A circuit tester (Figure 17.14) simply has two wire leads connected by a small lamp bulb, usually neon. Whenever one of the leads touches a hot wire and the other lead touches a grounded conductor completing the circuit, the bulb glows. The tester works only for a given voltage range, but most are able to handle both 110- and 220-volt circuits. The circuit tester is somewhat of a safety device in itself, enabling maintenance workers to be sure that power is turned off before touching hot wires. The circuit tester can also be used to determine whether various exposed parts of machines or conductors are *live* or *energized*.

Receptacle Wiring Tester

One of the simplest and most widely used test devices is the receptacle wiring tester, which can be carried around in one's pocket (see Figure 17.15). No battery or cord is required. The user simply plugs the device into any standard 110-volt outlet and interprets the arrangement of indicator lights to determine whether the receptacle is wired improperly. Note carefully the use of the word *improperly* instead of the word *properly* in the preceding sentence. Only certain errors will be detected, and a "correct" indication

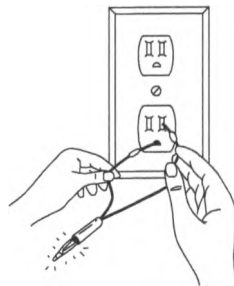

FIGURE 17.14
Circuit tester.

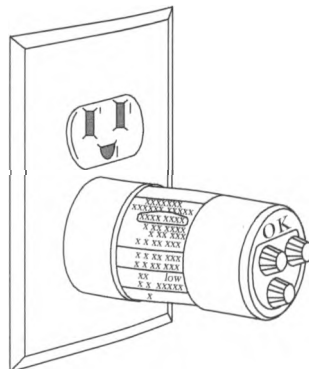

FIGURE 17.15
Receptacle wiring tester.

of the lights means only that those certain errors were not found. The receptacle could still be wired incorrectly.

Figure 17.16 reveals that the receptacle wiring tester is nothing more than three simple circuit testers combined into one tester. The tabular portion of the figure shows types of wiring errors that can be interpreted from the indicator lights. One of the most common wiring errors—"ground jumped to neutral"—is shown by the tester to be wired correctly.

Continuity Tester

It is sometimes useful to check a dead circuit simply to see whether all the connections are complete or whether a break in a conductor has occurred. Figure 17.17 illustrates a simple continuity tester, which is similar to a circuit tester except that a small battery is included to provide power for the light. The continuity tester also has much less electrical resistance than the circuit tester because it is used only on dead circuits. If the continuity tester is used on a live 110-volt circuit, it will immediately blow a fuse or throw a breaker in the circuit.

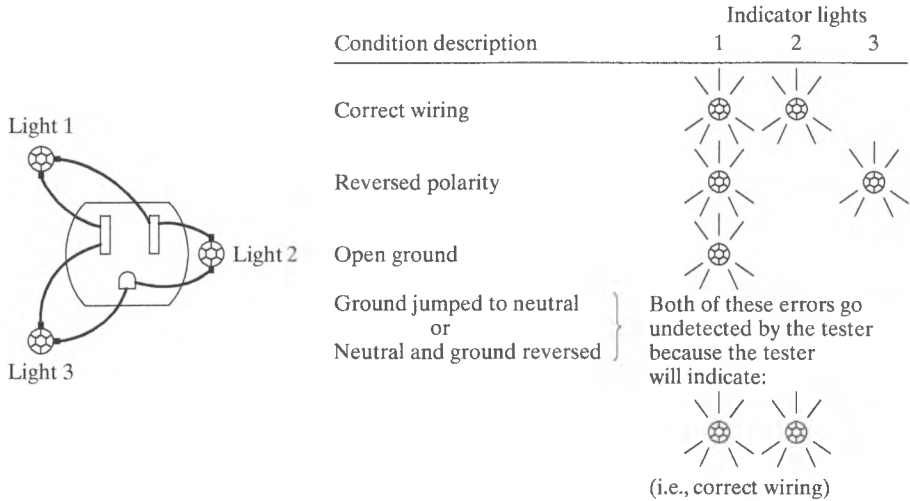

FIGURE 17.16 Schematic of receptacle wiring tester.

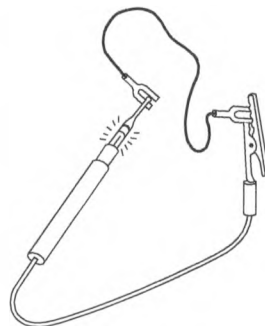

FIGURE 17.17 Continuity tester.

An important application for a continuity tester is to check the path to ground. One terminal of the tester can be connected to the exposed equipment case of a machine in question and the other terminal to a known-grounded object. If the lamp lights, the machine is known to be grounded. If the lamp does not light, there is a break somewhere in the path to ground.

EXPOSURE TO HIGH-VOLTAGE POWER LINES

Before closing this chapter with a summary of frequent electrical violations *inside* the workplace, we turn our attention *outside* the workplace to potential exposure to high-voltage power lines. Most people think of power-line exposures as applying to public utility workers, but hazards are lurking for such ordinary tasks as tree trimming, as Case Study 17.3 illustrates.

CASE STUDY 17.3

A worker was strapped to a tree working at a private residence in Fort Lauderdale, FL. He was using an aluminum pole saw for tree trimming and overhead power lines were approximately 8 feet away. For worker safety around power-line voltages, OSHA prescribes a minimum clearance of 10 feet. Depending upon atmospheric conditions, high-voltage power lines can arc and put the worker in danger even when actual contact with the conductor is not made. In this particular case, OSHA determined that the worker's aluminum pole saw actually made contact with the high-voltage power line and the worker was fatally electrocuted. There is no substitute for maintaining safe clearances. Had this workplace been in compliance with the OSHA standard and the worker and his pole saw were in the safe zone outside of 10 feet from the power line, this tragic worker fatality would not have occurred (OSHA cites South Florida tree trimming service in worker's fatal electrocution, 2016).

FREQUENT VIOLATIONS

Having been versed in the principles of electrical hazards, the safety and health manager should know what to look for when making an inspection. However, for review, the remainder of this chapter will describe frequently cited violations of the *National Electrical Code*[®].

Grounding of Portable Tools and Appliances

It should come as no surprise that the most frequently cited electrical code violation is for grounding. This is the code cited for ungrounded electric drills, sanders, saws, and other portable hand-held equipment. Nonportable equipment, such as refrigerators, freezers, and air conditioners, must also be grounded. Special attention should be given to the use of portable electric tools used in damp or wet locations and, of course, to plugs that have the ground pin broken off.

Exposed Live Parts

Almost as frequent as ungrounded portable equipment is the existence of exposed live parts. If the actual equipment conductors cannot be insulated and terminals covered, locked rooms should be used to prevent exposure to workers. One of the most frequent observations of exposed live parts is sloppy electrical installations in which covers are left off junction boxes or receptacle cover plates are missing. A switch box, fuse, or breaker box in which the door is open also constitutes “exposed live parts.”

Improper Use of Flexible Cords

Makeshift or temporary electrical installations are prohibited as are substitutions of flexible cords for fixed wiring. Obvious instances are flexible cords that run through holes in the walls, ceilings, floors, doorways, or windows.

Marking of Disconnects

This is an easy thing to correct. The disconnect box or switch panel for motors and appliances must be identified so that equipment can be quickly and confidently disconnected. Also, the origins of branch circuits, such as in the breaker box, must be labeled to indicate their purposes. If the location or arrangement of the disconnect makes the machines or circuits it controls obvious, marking may not be necessary. Very few of the disconnect marking violations are designated as “serious.”

Connection of Plugs to Cords

Here is another extremely simple item. When repairing a plug to an extension cord, appliance cord, or any other flexible cord, be sure to tie a knot in the cord or do something that will prevent a pull on the cord from being transmitted directly to joints or terminal screws. This is just a basic principle of electrical maintenance.

SUMMARY

This chapter began with some sobering thoughts of what electricity, even in small amounts, can do to the human body. The greatest hazard is with 110-volt circuits, not 220-volt or higher circuits. This is because of the popularity of 110-volt circuits and the complacency of the people who use them. Besides electrocution hazards, electricity also presents fire hazards, not to speak of burns and other electrical exposure hazards.

Simple testers can demonstrate quickly some of the frequent wiring mistakes that might otherwise go undetected in normal operations. However, some of these testers are too simple and overlook common errors such as “ground jumped to neutral.”

Providing for electrical equipment in industrial processes that produce flammable vapors, dusts, or fibers is a difficult and expensive task. The definitions and codes for hazardous locations with explosive atmospheres are also complicated and tricky. The safety and health manager is advised to look for required markings on electrical equipment installed in hazardous locations to be sure that the equipment is approved for the “Class” and “Division” of the location in which it has been installed.

Violations of electrical code are often for conditions that are easy to correct. The largest single item to remember is grounding—grounding of both portable and fixed equipment and the circuits that serve them. Of less frequency, but of great seriousness, are the OSHA citations for unapproved conduit and electrical equipment used in explosive atmospheres of flammable vapors or dusts.

EXERCISES AND STUDY QUESTIONS

- 17.1 What are the two principal hazards of electricity?
- 17.2 Identify at least three sets of conditions that can increase the likelihood of electrocution.
- 17.3 Compare 110-, 220-, and 440-volt hazards of electricity.
- 17.4 At approximately what current levels through the heart and lungs does the sustained flow of electricity become fatal?
- 17.5 What part does grounding play in an electrical circuit? Why do safety regulations require equipment to be grounded?
- 17.6 Compare the functions of hot, neutral, and ground wires.
- 17.7 What is a GFCI, and where is it used?
- 17.8 Explain the term *double insulation*.
- 17.9 What are the hazards of reversed polarity?
- 17.10 Compare electrical “arcs” and “sparks.”
- 17.11 Explain the difference among Class I, II, and III hazardous locations.
- 17.12 What do the terms *Division* and *Group* mean in the classification of hazardous locations?
- 17.13 Explain the difference between a continuity tester and a circuit tester.
- 17.14 Name some of the most frequent violations of electrical code.
- 17.15 A certain string of Christmas tree lights has eight bulbs, each rated at 5 watts. If there is no ground fault, how much current flows through the hot wire at the receptacle plug? How much flows through the neutral?
- 17.16 In Exercise 17.15, if all the current flowing through the hot wire would pass through a person’s heart muscle, would the current likely be fatal?
- 17.17 A maintenance worker wires a 110-volt electric lamp without disconnecting the circuit. With no load energized in the circuit, the worker accidentally contacts the bare hot wire. What will probably happen? Under what conditions would the worker likely be killed?
- 17.18 In Exercise 17.17, suppose the wire that was contacted was the neutral wire. What would probably happen? Are there conditions under which the worker would be killed?
- 17.19 In Exercise 17.17, suppose the wire that was contacted was the equipment ground wire. What would probably happen?
- 17.20 Portable “trouble lights” used in automobile repair have been involved in many fatalities. Explain probable hazard mechanisms.
- 17.21 Explain the difference between a GFCI and an ordinary circuit breaker.
- 17.22 Explain why it is so difficult to detect the wiring defect “ground jumped to neutral.”
- 17.23 A worker was electrocuted when he drilled through a wall and the drill bit contacted an electrical wire inside the wall by cutting through its insulation. The ground pin of the electric plug for the drill was broken off. Describe several ways in which this fatality could have been prevented.
- 17.24 The broken-off ground pin represented a code violation in the fatality case described in Exercise 17.23. How did this contribute to the hazard? What would probably have happened had the ground pin been intact?
- 17.25 It can be said that “grounding” with respect to electricity can be both good and bad. Explain the “good” and the “bad” about electrical grounding.

- 17.26** Explain the distinction between the terms “grounded conductor” and “grounding conductor.”
- 17.27** For each of the following situations, explain the nature of the hazard and describe probable outcomes:
- (a) A worker brushes his pant leg across a 120-volt terminal strip with screw terminals exposed. Every other screw is hot, with neutral screws intervening.
 - (b) A worker’s boot contacts a 440-volt bus bar. A ground path occurs through the worker’s foot and the nails in the sole of the boot to the concrete floor. The resistance of the ground path is 10,000 ohms.
 - (c) A worker wires a 220-volt circuit “hot” using a wood-handle screwdriver. The screwdriver slips, and the shaft of the screwdriver makes a direct short across the hot terminal and the adjacent neutral.
 - (d) A worker changes a 120-volt wall receptacle in a garage while standing on a concrete floor. The circuit is energized, but the worker is careful not to touch both the hot wire and the neutral wire at the same time.
- 17.28** A right-handed worker is repairing a 120-volt lamp socket using a screwdriver with an insulated handle. He is wearing a short-sleeve shirt, and his bare right arm is braced against a water pipe. A bare hot wire contacts the metal housing of the socket assembly the worker is holding in his hand while he is using the screwdriver in his other hand. A ground path occurs with total resistance of 600 ohms. Calculate the current flow and describe its probable path. Will the breaker likely be tripped? Is there a risk of electrocution? If so, what factors contribute to the risk?
- 17.29** Describe the phenomenon of fibrillation and its probable effect.
- 17.30** What characteristic about electric utility power aggravates the hazard of fibrillation?
- 17.31** Calculate the peak voltage for an effective line voltage of 240 volts ac.
- 17.32** An ac circuit has peak voltages of ± 80 volts. Calculate the effective voltage.
- 17.33** An ac circuit has peak voltages of ± 170 volts. Calculate the *effective* current flow in this circuit if the total circuit load operates at 60 watts of power. Calculate the peak current flow.
- 17.34** Explain why it is so important for the resistance to be low in the “third-wire” path to ground. (*Hint*: “Electricity follows the path of least resistance” is not the correct answer to this question.)
- 17.35** Explain how a “shorted-out” electric tool may continue to operate. There are at least two different sets of conditions that will lead to this phenomenon.
- 17.36** Explain why the common wiring defect “open ground” easily goes undetected.
- 17.37** Is it okay to use Division 1 approved equipment in Division 2 hazardous locations? Why or why not? Is it okay to use Class I approved equipment in Class II hazardous locations? Why or why not?
- 17.38** Is it a hazard to substitute a 20-ampere fuse for a 30-ampere fuse? Explain.
- 17.39** Explain why there are different levels or ratings for fuses or circuit breakers. Why is it a hazard to substitute a fuse of a higher rating?
- 17.40** Fuses and circuit breakers are primarily for the purpose of protection from which of the two principal hazards from electricity? What is the other principal hazard? Do fuses and circuit breakers help mitigate this hazard also? If so, how?
- 17.41** What is the hazard of substituting a penny or other low resistance electrical connection in lieu of a fuse or circuit breaker?
- 17.42** What is a weatherproof outlet? Is it approved for Class I, Division 1 locations? Is it approved for Division 2 locations? Why or why not?
- 17.43** What happens when a continuity tester is used in place of a circuit tester?

- 17.44 Identify two receptacle wiring mistakes that go undetected by a receptacle wiring tester.
- 17.45 What simple procedure in the repair of an electric plug will prevent a commonly cited violation of electrical code?
- 17.46 Is it okay to use an extension cord to connect an appliance in another room through a hole in the wall?
- 17.47 When a wall receptacle outlet has a missing plate cover, what is the electrical code violation?
- 17.48 Calculate the energy released in an arc flash at 480 volts in which the fault current is 8000 amperes and the duration of the fault is 5 cycles on a 60-Hz circuit.
- 17.49 Which electrical tester requires a battery?
- 17.50 A GFCI detects ground faults by comparing current flows in which two wires?
- 17.51 The ground wire of a circuit is inadvertently connected to a grounded object along the circuit. Will the GFCI detect it?
- 17.52 Which of the three wires in a conventional circuit is ignored by the GFCI?
- 17.53 What is the difficulty with relying upon a defibrillation device to restore natural heart rhythm?
- 17.54 What effect of electrical shock is treated the same as for a near-drowning victim?
- 17.55 Almost everyone has received a shock from a household electrical outlet and survived. Does this mean that household circuits are not powerful enough to be dangerous?
- 17.56 When an ordinary household circuit breaker is tripped by current overflow that happens to flow through a person's heart muscle, how much greater than a lethal dose is the person receiving?
- 17.57 What hazard mechanism makes ordinary 110-volt circuits even more dangerous than 220-volt or higher circuits?
- 17.58 What common error in wiring is not detected by ordinary circuit testers?
- 17.59 What easily corrected violation of electrical codes is the largest single item to remember?
- 17.60 If electrical equipment cannot be insulated and terminals covered, what should be used to protect workers?
- 17.61 **Design Case Study.** In an actual case history of an electrocution fatality, Figure 17.18(a) illustrates the way the chuck key for a hand-held electric drill was conveniently attached to the power cord so that it would always be readily available for operator use in changing bits. The fatality occurred when the twisted wire wore through the cord insulation after continued use. Figure 17.18(b) illustrates a much safer way to connect the chuck key. What other factors probably contributed to this fatality and how could it have been prevented? Suppose that the

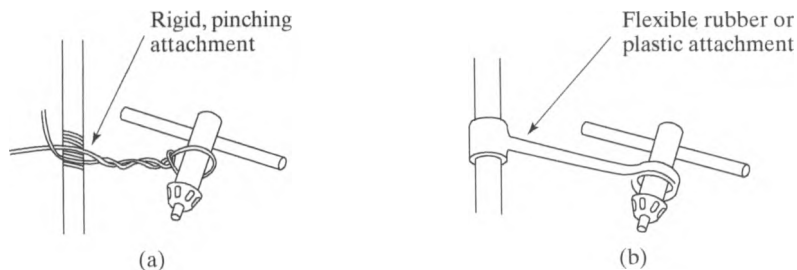

FIGURE 17.18

Cause of electrocution fatality: chuck key secured to cord by twisted wire tie. (a) Unsafe, improvised attachment of chuck key. Wire or tape will eventually damage cord insulation. (b) Safer method of attaching chuck key.

ground pin had been broken off the plug for this drill. How would this code violation have affected this fatality?

- 17.62 Design Case Study.** An architectural design and engineering firm seeks advice regarding federal safety standards for wiring for a new process being set up to manufacture dyestuff. The process uses chlorobenzene and releases ignitable concentrations in the vicinity of the process equipment. Specify the appropriate Class, Division, and Group classification for wiring and electrical equipment located in this area.
- 17.63 Design Case Study.** In the case study of Exercise 17.62, suppose an alternate supplier of process equipment proposes a completely closed system in which releases would only occur during repair or in event of a leak. Such occurrences arise frequently out of a need to regularly clean the in-feed mechanism. Would the closed system have an impact on safety and on the prescribed wiring system?

RESEARCH EXERCISES

- 17.64** Check news reports about a multiple electrocution accident in a water park in Turkey, in 2017.
- 17.65** Find sources of assistance in education about water and electrocution.
- 17.66** Use the Internet to find out who publishes the *National Electrical Code*[®]. What other aids for electrical safety are available from this organization?
- 17.67** Check recent statistics to determine the number of electrocutions annually in the United States. What percentage is “on the job”? Is the annual number of electrocutions increasing or decreasing?
- 17.68** OSHA citation frequencies change somewhat from year to year. Check enforcement statistics to determine the top five most frequently cited electrical standards. Are they the same as the ones identified in this chapter?

STANDARDS RESEARCH QUESTIONS

- 17.69** This chapter concludes those related to the General Industry standards. If the reader has been studying the chapters of this book sequentially, then at this point he or she should have a great deal of familiarity with the OSHA General Industry standards and the database tool on the Companion Website for examining inspection statistics for these standards. In previous chapters, this text has assigned specific questions for “STANDARDS RESEARCH QUESTIONS.” In this chapter, however, rather than address specific questions for research related to electrical standards, it is suggested that the reader go “browsing” in the OSHA General Industry electrical standards, using the OSHA website. Try to relate the standards to topics that were discussed in this chapter. Try to pick out particular provisions in the OSHA standard that you reason would be frequently cited. Check whether your theories are correct by researching statistics on the OSHA website. Try to pick out standards that OSHA would cite as “serious” violations in many cases.